



ATLAS 170

The Atlas Battery System is a future-proof energy source that provides on-demand energy needed for massive fleet trucks and vehicles and enables a fast seamless transition to renewable energy. No matter the renewable energy source or power requirement, Atlas can handle it. Endless Atlas units can be linked together to provide Megawatt-scale power wherever the grid falls short.

FLEET CHARGING



HEAVY CONSTRUCTION



EMERGENCY RESPONSE

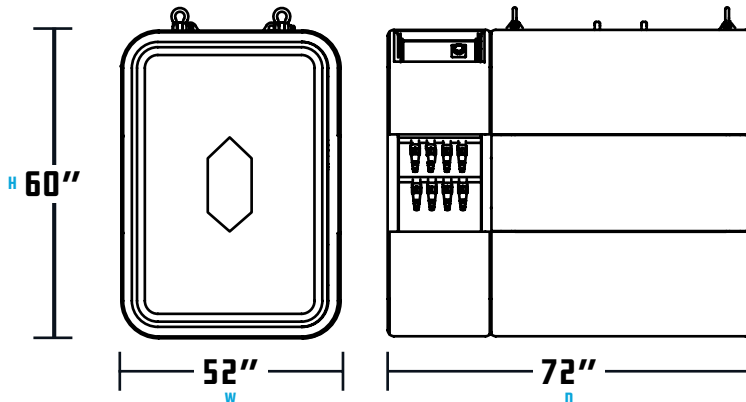

USABLE ENERGY (C/5)	170kWh
OUTPUT VOLTAGE	500 - 1500VDC, programmable
OUTPUT CONNECTION	CCS level 3 DC with optional cable
OUTPUT POWER	100kW max.
CHEMISTRY	LFP
CYCLE LIFE TO 70% INITIAL CAPACITY	> 6000
MAXIMUM DISCHARGE RATE	100kW continuous; 150kW for 10 seconds
CHARGING INPUT, DC	CCS combo 2 connector, Level 3, 535 - 700VDC
CHARGING INPUT, AC	CCS combo 2 connector, Level 2, 12kW internal charger
MAXIMUM CHARGE RATE	85kW
CHARGE TIME, LEVEL 2	~ 15 hours
CHARGE TIME, LEVEL 3	~ 3 hours
DAISY-CHAIN CAPABLE	Yes
DIMENSIONS	60" H x 72" D x 52" W
DISPLAY	LCD
WEIGHT	~ 5000 lbs.
TRAILER OPTION	Yes
OPERATING TEMPERATURE RANGE	-20°C to +55°C
THERMAL MANAGEMENT SYSTEM	Internal liquid cooling / heating
REMOTE MANAGEMENT	IoT and GPS enabled for diagnostics, control, and billing
CERTIFICATIONS	TBD